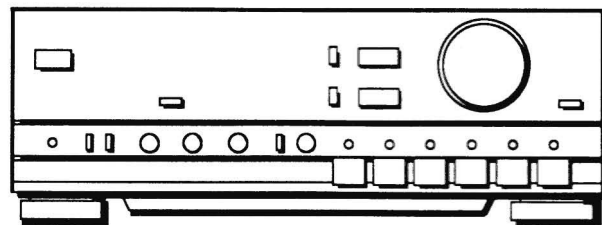

AIWA®**XA-007****SERVICE
MANUAL**

STEREO INTEGRATED AMPLIFIER

• TYPE. H,E,K,Z

SPECIFICATIONS

Common

Power requirements	XA-007E, Z 220 V, 50 Hz XA-007K, 240 V, 50Hz XA-007H 120 V/220 V/240 V (switchable), 50/60 Hz
Power consumption	XA-007E, K, Z 380 W XA-007H 125 W
Power amplifier	
Effective output power	80 W+80 W (4-8 ohms, T.H.D. 0.9%, 1 kHz)
Total harmonic distortion	0.007% (20 Hz-20 kHz, 65 W, 8 ohms)
Output bandwidth	20 Hz-20 kHz (less than 0.05%) [Both channels driven, 8 ohms]
Frequency response	5 Hz-100 kHz (0/-3 dB)

**Preamplifier
S/N ratio**

IHF A curve short circuited PHONO (MM)	94 dB (5 mV INPUT)
PHONO (MC)	75 dB (0.5 mV INPUT)
TUNER, DAT, VCR (AUX), TAPE	105 dB

**Input jacks
(Sensitivity/Input impedance)**

PHONO (MM)	2.5 mV/47 kohms
PHONO (MC)	0.2 mV/100 ohms
TUNER, DAT, VCR (AUX), TAPE	150 mV/47 kohms
CD	150 mV/47 kohms

PHONO overload level MM 150 mV
[1 kHz, THD 0.01%]

**Output jacks
(Level/output impedance)**

TAPE	150 mV/47 kohms
Headphones	8-32 ohms
Speakers	4-16 ohms (A+B: 8-16 ohms)

RIAA deviation ±0.5 dB (30 Hz-15 kHz)

Dimensions 430(W) × 140(H) × 335(D) mm
Weight 8.4 kg

• Design and specifications are subject to change without notice.

AIWA Co., Ltd.**Tokyo Japan**

Printed in Japan

ELECTRICAL MAIN PARTS LIST

REF. NO.	PART NO.	DESCRIPTION	REF. NO.	PART NO.	DESCRIPTION
===IC===					
	87-001-171-019	IC, NJM2068D	C206	*87-010-260-019	CAP. ELECT 47-25V
	87-027-787-019	IC, UPC1237H	C207	*87-010-260-019	CAP. ELECT 47-25V
===TRANSISTOR===					
	89-501-706-019	FET, 2SK170BL/V	C208	*87-010-260-019	CAP. ELECT 47-25V
	89-110-155-019	TRANSISTOR, 2SA1015(GR)	C209	*87-010-260-019	CAP. ELECT 47-25V
	89-111-453-019	TRANSISTOR, 2SA1145(O)	C210	*87-010-260-019	CAP. ELECT 47-25V
	89-113-013-010	TRANSISTOR, 2SA1301(O)	C221	*87-018-131-019	CAP. CERA-SOL SS 1000P(Z)
	89-113-583-010	TRANSISTOR, 2SA1358	C222	*87-018-131-019	CAP. CERA-SOL SS 1000P(Z)
	89-109-705-019	TRANSISTOR, 2SA970 GR	C231	*87-014-210-010	CAP. MYLAR 0.047-250V(Z)
	89-210-155-019	TRANSISTOR, 2SB1015	C232	*87-014-210-010	CAP. MYLAR 0.047-250V(Z)
	89-318-155-019	TRANSISTOR, 2SC1815(GR)	C241	*87-010-430-019	CAP. ELECT 100-63
	89-322-405-019	TRANSISTOR, 2SC2240(GR)	C242	*87-010-430-019	CAP. ELECT 100-63
	89-322-591-010	TRANSISTOR, 2SC2259F	J2	87-009-023-019	JACK PIN YKC21-0349(PHONO)(TUNER)
	89-327-053-010	TRANSISTOR, 2SC2705(O)	J3	87-049-868-019	JACK PIN 4P(CD)(VCR/AUX)
	89-332-803-010	TRANSISTOR, 2SC3280(O)	J4	87-049-868-019	JACK PIN 4P(TAPE2/DAT)
	89-334-194-019	TRANSISTOR, 2SC3419Y	J5	87-049-868-019	JACK PIN 4P(TAPE1)
	89-334-213-010	TRANSISTOR, 2SC3421	L1	*87-005-158-010	COIL 1UH
	89-414-065-019	TRANSISTOR, 2SD1406 GR	L2	*87-005-158-010	COIL 1UH
===DIODE===					
	87-020-110-019	DIODE 1SS177	L3	*87-007-265-010	COIL 100UH(Z)
	87-027-788-010	DIODE D5FB20	L4	*87-007-265-010	COIL 100UH(Z)
	87-020-123-019	DIODE DS446	LED1	87-001-779-019	LED SLH56VC RED-F(PHONO IND.)
	87-020-945-010	DIODE MPG06D	LED2	87-001-779-019	LED SLH56VC RED-F(TUNER IND.)
	87-027-449-019	DIODE, ZENER HZ15-3L	LED3	87-001-779-019	LED SLH56VC RED-F(CD IND.)
	87-027-416-019	DIODE, ZENER HZ3C2	LED4	87-001-779-019	LED SLH56VC RED-F(VCR/AUX IND.)
			LED5	87-001-779-019	LED SLH56VC RED-F(TAPE2/DAT IND.)
===MAIN CIRCUIT BOARD SECTION===					
△	*87-033-147-019	FUSE CLAMP	LED6	87-001-779-019	LED SLH56VC RED-F(TAPE1 IND.)
C1	*87-018-125-019	CAP. CERA-SOL SS 330P	△R115	*87-029-130-019	RES. FUSE 220-1W
C2	*87-018-125-019	CAP. CERA-SOL SS 330P	△R116	*87-029-130-019	RES. FUSE 220-1W
C3	*87-012-110-019	CAP. CERA-SOL 270P BEAD(Z)	R117	*87-025-434-010	RES. CEMENT 0.22-5W
C4	*87-012-110-019	CAP. CERA-SOL 270P BEAD(Z)	R118	*87-025-434-010	RES. CEMENT 0.22-5W
C19	*87-018-128-019	CAP. CERA-SOL SS 560P	R119	*87-025-434-010	RES. CEMENT 0.22-5W
C20	*87-018-128-019	CAP. CERA-SOL SS 560P	R120	*87-025-434-010	RES. CEMENT 0.22-5W
C21	*87-010-263-019	CAP. ELECT 100-10V	R123	*87-025-347-010	RES. METAL 10-2W
C22	*87-010-263-019	CAP. ELECT 100-10V	R124	*87-025-347-010	RES. METAL 10-2W
C23	*87-010-404-019	CAP. ELECT 4.7-50V SME	R125	*87-025-120-010	RES. MFO 10-1W
C24	*87-010-404-019	CAP. ELECT 4.7-50V SME	R126	*87-025-120-010	RES. MFO 10-1W
C31	*87-010-260-019	CAP. ELECT 47-25V	△R201	87-029-094-019	RES. FUSE 15-1/4W
C32	*87-010-260-019	CAP. ELECT 47-25V	△R202	87-029-094-019	RES. FUSE 15-1/4W
C41	*87-010-405-019	CAP. ELECT 10-50V SME	△R227	87-029-082-019	RES. FUSE 100 1/4W
C42	*87-010-405-019	CAP. ELECT 10-50V SME	△R228	87-029-082-019	RES. FUSE 100 1/4W
C45	*87-018-127-019	CAP. CERA-SOL SS 470P	△R243	87-029-089-019	RES. FUSE 4.7 1/4W
C46	*87-018-127-019	CAP. CERA-SOL SS 470P	△R244	87-029-089-019	RES. FUSE 4.7 1/4W
C49	*87-010-263-019	CAP. ELECT 100-10V	RY1	87-045-281-010	RELAY, G5R24V SP
C50	*87-010-263-019	CAP. ELECT 100-10V	SW1	89-AA1-630-019	PUSH SW(PHONO)
C61	*87-018-103-019	CAP. CERA-SOL SS 8.2P	SW2	+	PUSH SW(TUNER)
C62	*87-018-103-019	CAP. CERA-SOL SS 8.2P	SW3	+	PUSH SW(CD)
C65	*87-018-131-019	CAP. CERA-SOL SS 1000P	SW4	+	PUSH SW(VCR/AUX)
C66	*87-010-762-019	CAP. ELECT 220-10 BP	SW5	+	PUSH SW(TAPE2/DAT)
C68	*87-010-404-019	CAP. ELECT 4.7-50V SME	SW6	+	PUSH SW(TAPE1)
C69	*87-010-260-019	CAP. ELECT 47-25V	SW15	89-AA1-633-019	PUSH SW(CARTRIDGE)
C70	*87-010-401-019	CAP. ELECT 1-50V	SW16	89-AA1-639-010	ROTARY SW(REC OUT)
C92	*87-018-134-019	CAP. CERA-SOL SS 0.01(Z)	SFR1	*87-024-169-019	SFR 2.2K
C93	*87-010-384-019	CAP. ELECT 100-25V	SFR2	*87-024-169-019	SFR 2.2K
C94	*87-010-384-019	CAP. ELECT 100-25V	===FRONT CIRCUIT BOARD SECTION===		
C95	*87-018-121-019	CAP. CERA-SOL SS 150P(Z)	C151	*87-018-126-019	CAP. CERA-SOL SS 390P
C96	*87-018-121-019	CAP. CERA-SOL SS 150P(Z)	C152	*87-018-126-019	CAP. CERA-SOL SS 390P
C97	*87-018-121-019	CAP. CERA-SOL SS 150P(Z)	C155	*87-010-401-019	CAP. ELECT 1-50V
C201	*87-010-765-019	CAP. ELECT 10000-63	C156	*87-010-401-019	CAP. ELECT 1-50V
C202	*87-010-765-019	CAP. ELECT 10000-63	C157	*87-018-121-019	CAP. CERA-SOL SS 150P
C203	*87-010-411-019	CAP. ELECT 1000-50 SME	C158	*87-018-121-019	CAP. CERA-SOL SS 150P
C204	*87-010-411-019	CAP. ELECT 1000-50 SME	C159	*87-010-403-019	CAP. ELECT 3.3-50V SME
C205	*87-010-260-019	CAP. ELECT 47-25V	C160	*87-010-403-019	CAP. ELECT 3.3-50V SME
			C167	*87-018-123-019	CAP. CERA-SOL 220P
			C168	*87-018-123-019	CAP. CERA-SOL 220P
			C171	*87-010-260-019	CAP. ELECT 47-25V
			C172	*87-010-260-019	CAP. ELECT 47-25V
			C173	*87-010-404-019	CAP. ELECT 4.7-50V SME
			C174	*87-010-404-019	CAP. ELECT 4.7-50V SME

REF. NO.	PART NO.	DESCRIPTION	REF. NO.	PART NO.	DESCRIPTION
C175	*87-018-129-019	CAP, CERA-SOL SS 680P	△	*87-085-184-010	AC CORD BUSHING D(H)
C176	*87-018-129-019	CAP, CERA-SOL SS 680P	△	*87-085-185-010	AC CORD BUSHING E(E, K, Z)
C177	*87-010-401-019	CAP, ELECT 1-50V	△J7	87-049-416-010	AC OUTLET K-N(AC OUTLET)(K)
C178	*87-010-401-019	CAP, ELECT 1-50V	△J7	87-049-017-019	AC OUTLET(AC OUTLET)(H)
C179	*87-010-404-019	CAP, ELECT 4. 7-50V SME	△PT1	89-AA1-608-019	POWER TRANSFORMER E(E, Z)
C180	*87-010-404-019	CAP, ELECT 4. 7-50V SME	△PT1	89-AA1-606-019	POWER TRANSFORMER H(H)
C181	*87-010-260-019	CAP, ELECT 47-25V	△PT1	89-AA1-609-019	POWER TRANSFORMER K(K)
C182	*87-010-260-019	CAP, ELECT 47-25V			
LED10	87-001-779-019	LED SLH56VC RED-F(CD DIRECT IND.)			
LED11	87-001-779-019	LED SLH56VC RED-F(MUTING IND.)			
SW10	87-036-179-019	PUSH SW(LOUDNESS)			
SW11	87-036-180-019	PUSH SW(CD DIRECT)			
SW12	87-036-180-019	PUSH SW(MUTING)			
SW14	87-036-179-019	PUSH SW(TONE DEFEAT)			
VR1	81-777-630-019	VOLUME 100KB(VOLUME)			
VR2	81-777-631-019	VOLUME 100K MN(BALANCE)			
VR3	81-777-632-019	VOLUME 50KC(BASS)			
VR4	81-777-632-019	VOLUME 50KC(TREBLE)			
===SP TERMINAL CIRCUIT BOARD SECTION===					
C223	*87-018-134-019	CAP, CERA-SOL SS 0.01(Z)			
C224	*87-018-134-019	CAP, CERA-SOL SS 0.01(Z)			
C225	*87-018-134-019	CAP, CERA-SOL SS 0.01(Z)			
C226	*87-018-134-019	CAP, CERA-SOL SS 0.01(Z)			
C227	*87-018-133-019	CAP, CERA-SOL 4700P(Z)			
C228	*87-018-133-019	CAP, CERA-SOL 4700P(Z)			
C235	*87-018-133-019	CAP, CERA-SOL 4700P(Z)			
C236	*87-018-133-019	CAP, CERA-SOL 4700P(Z)			
C237	*87-018-133-019	CAP, CERA-SOL 4700P(Z)			
C238	*87-018-133-019	CAP, CERA-SOL 4700P(Z)			
J6	*87-033-192-010	SPEAKER TERMINAL 8P(SPEAKERS)			
L5	*87-005-158-010	COIL 1UH(Z)			
L6	*87-005-158-010	COIL 1UH(Z)			
L7	*87-005-158-010	COIL 1UH(Z)			
L8	*87-005-158-010	COIL 1UH(Z)			
===SP+HP CIRCUIT BOARD SECTION===					
J1	87-009-169-010	JACK 6.3 STAU(PHONES)			
R143	*87-025-458-010	RES, METAL 470-2W			
R144	*87-025-458-010	RES, METAL 470-2W			
SW8	89-AA1-632-019	PUSH SW(SPEAKER A)			
SW9	89-AA1-632-019	PUSH SW(SPEAKER B)			
===POWER SW CIRCUIT BOARD SECTION===					
△	*87-033-147-019	FUSE CLAMP(E, K, Z)			
△C87	*87-019-112-019	CAP, LINE 0.01(E, K, Z)			
△C87	*87-019-110-019	SPARK KILLER 0.01D(H)			
△FU3	87-035-365-010	FUSE T2A(E, K, Z)			
△SW7	87-036-034-019	PUSH SW(POWER)			
===AC VOLTAGE CIRCUIT BOARD SECTION (H MODEL)===					
△	*87-033-147-019	FUSE CLAMP(H)			
△FU5	87-035-366-010	FUSE T2.5A(H)			
△FU6	87-035-366-010	FUSE T2.5A(H)			
△SW18	87-036-067-019	SLIDE SW(AC VOLTAGE)(H)			
===OUTLET CIRCUIT BOARD SECTION (E, Z MODEL)===					
△	*87-033-147-019	FUSE CLAMP(E, Z)			
△FU4	87-035-366-010	FUSE T2.5A(E, Z)			
△J7	87-049-514-010	AC OUTLET E(AC OUTLET)(E, Z)			
===SEL IMP CIRCUIT BOARD SECTION===					
SW17	87-036-181-019	SLIDE SW(SPEAKER IMPEDANCE)			
===MISCELLANEOUS===					
△	*82-187-796-019	AC CORD (BS)(K)			
△	*82-187-797-019	AC CORD (E)(E, Z)			
△	*87-034-749-019	AC CORD (H)(H)			

IC BLOCK DIAGRAM

- IC, UPC1237H

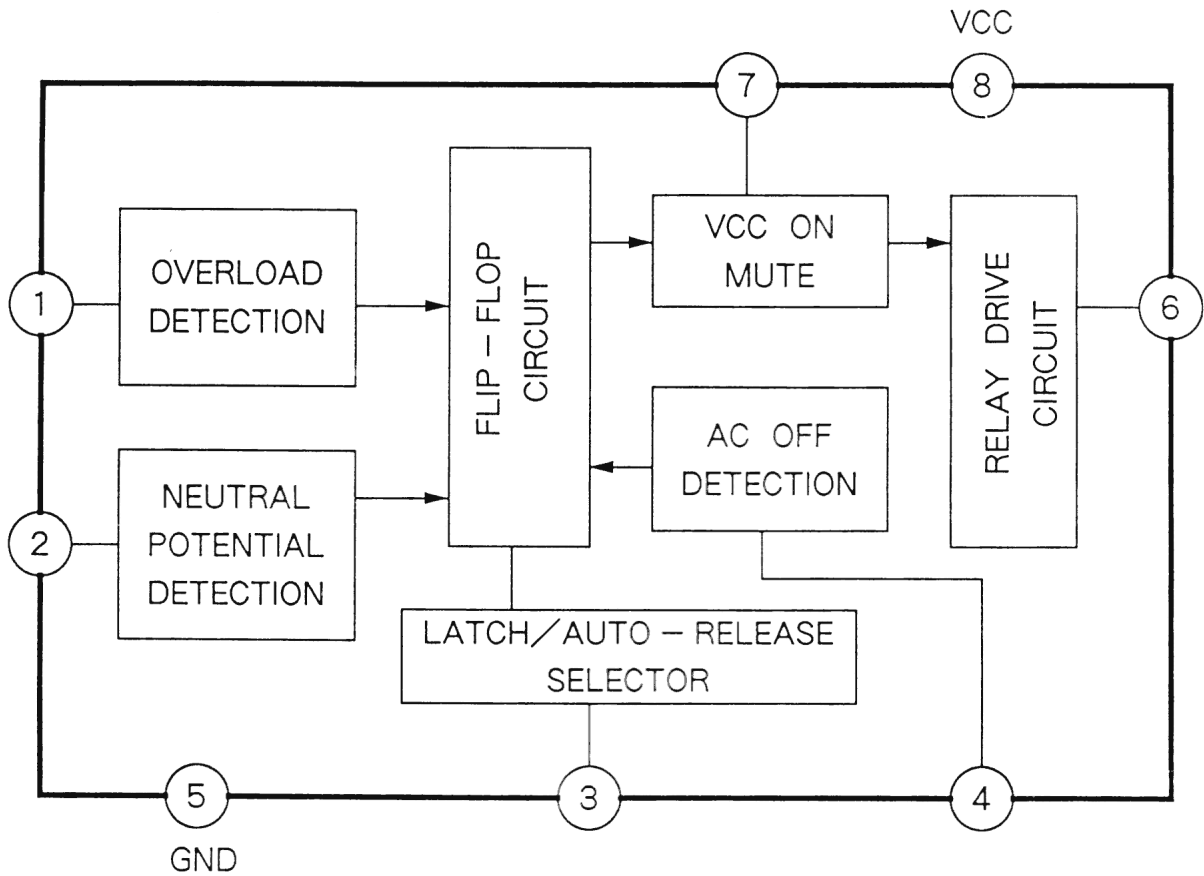

2SA1015
2SA970
2SC1815
2SC2240

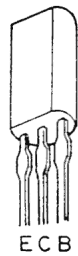

2SA1145
2SC2705

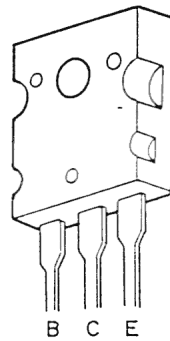

2SA1301
2SC3280

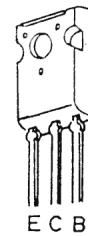

2SA1358
2SC3419
2SC3421

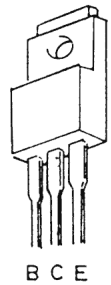

2SB1015
2SD1406

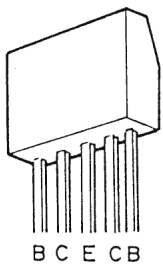

2SC2259

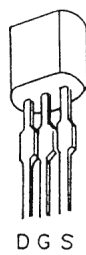

2SK170

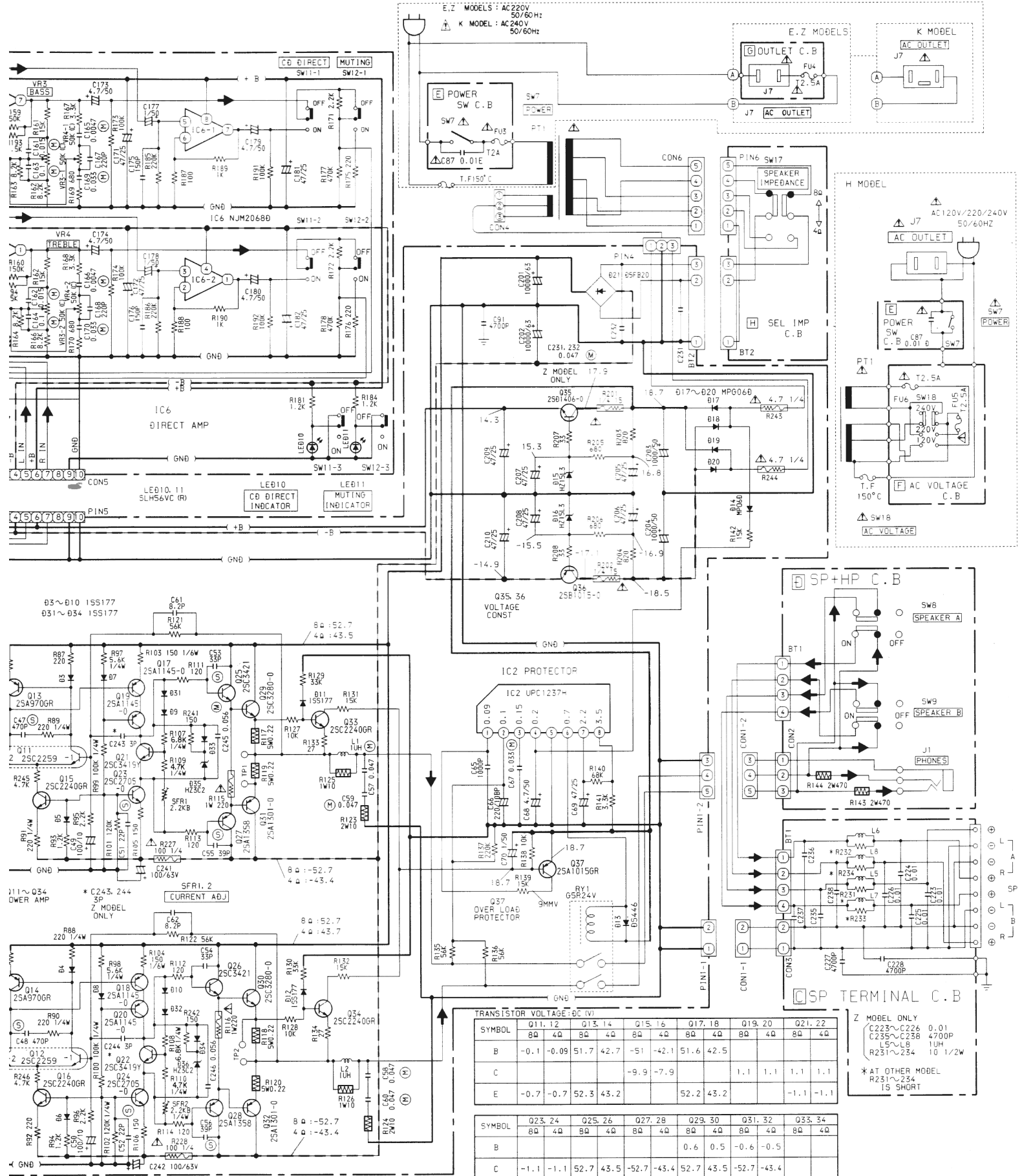

TRANSISTOR VOLTAGE: 0C (V)

SYMBOL	Q11, 12		Q13, 14		Q15, 16		Q17, 18		Q19, 20		Q21, 22	
	8Ω	4Ω	8Ω	4Ω	8Ω	4Ω	8Ω	4Ω	8Ω	4Ω	8Ω	4Ω
B	-0.1	-0.09	51.7	42.7	-51	-42.1	51.6	42.5				
C					-9.9	-7.9			1.1	1.1	1.1	1.1
E	-0.7	-0.7	52.3	43.2			52.2	43.2			-1.1	-1.1

SYMBOL	Q23, 24		Q25, 26		Q27, 28		Q29, 30		Q31, 32		Q33, 34	
	8Ω	4Ω	8Ω	4Ω	8Ω	4Ω	8Ω	4Ω	8Ω	4Ω	8Ω	4Ω
B					0.6	0.5	-0.6	-0.5				
C	-1.1	-1.1	52.7	43.5	-52.7	-43.4	52.7	43.5	-52.7	-43.4		
E	-51.6	-42.8	0.6	0.5	-0.6	-0.5						

Z MODEL ONLY
 C223~C226 0.01
 C235~C238 4700P
 L5~L8 1UH
 R231~234 10 1/2W
 * AT OTHER MODEL
 R231~234 1S SHORT

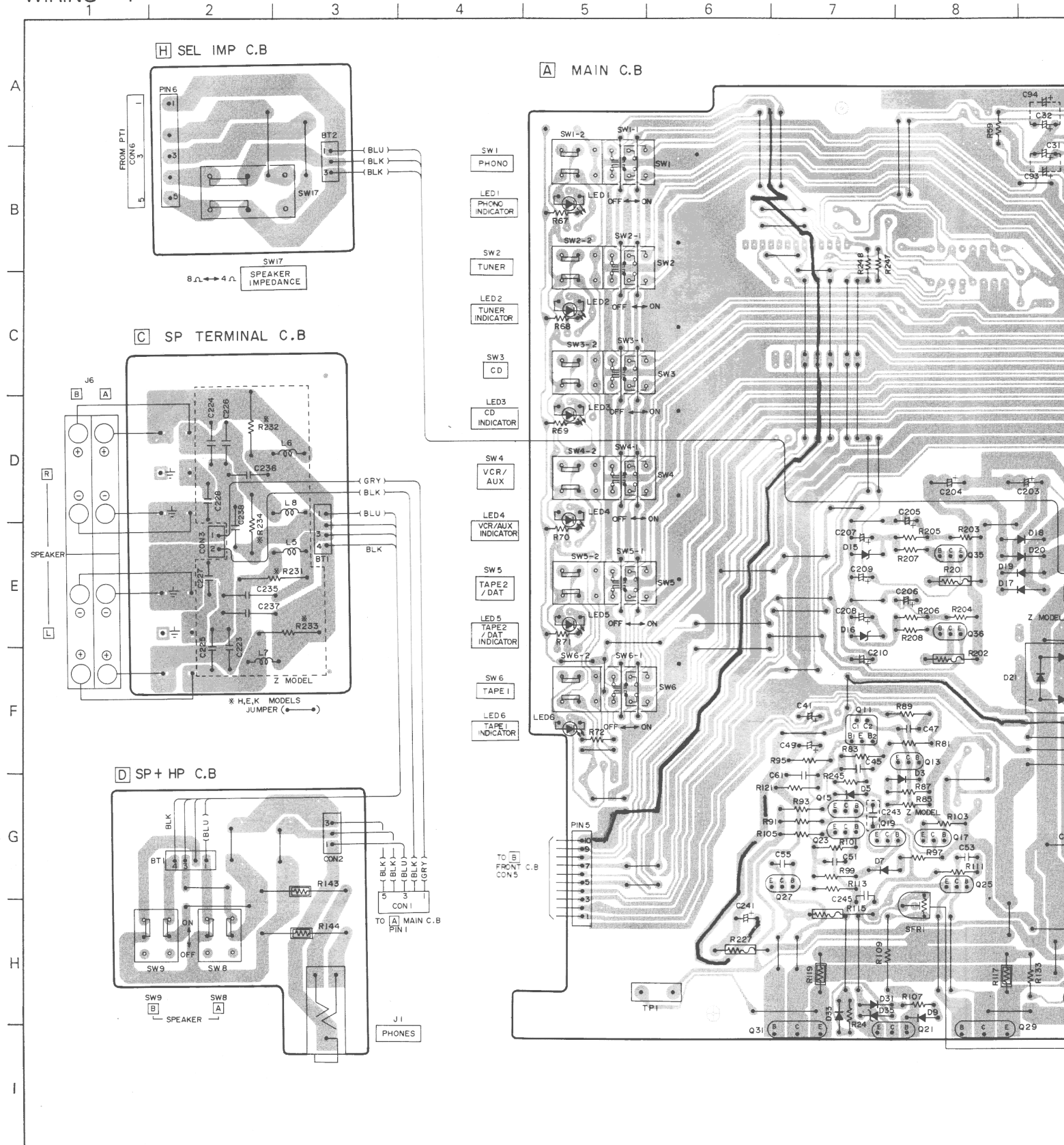

SW16 REC OUT SELECTOR SW15 CARTRIDGE MM MC

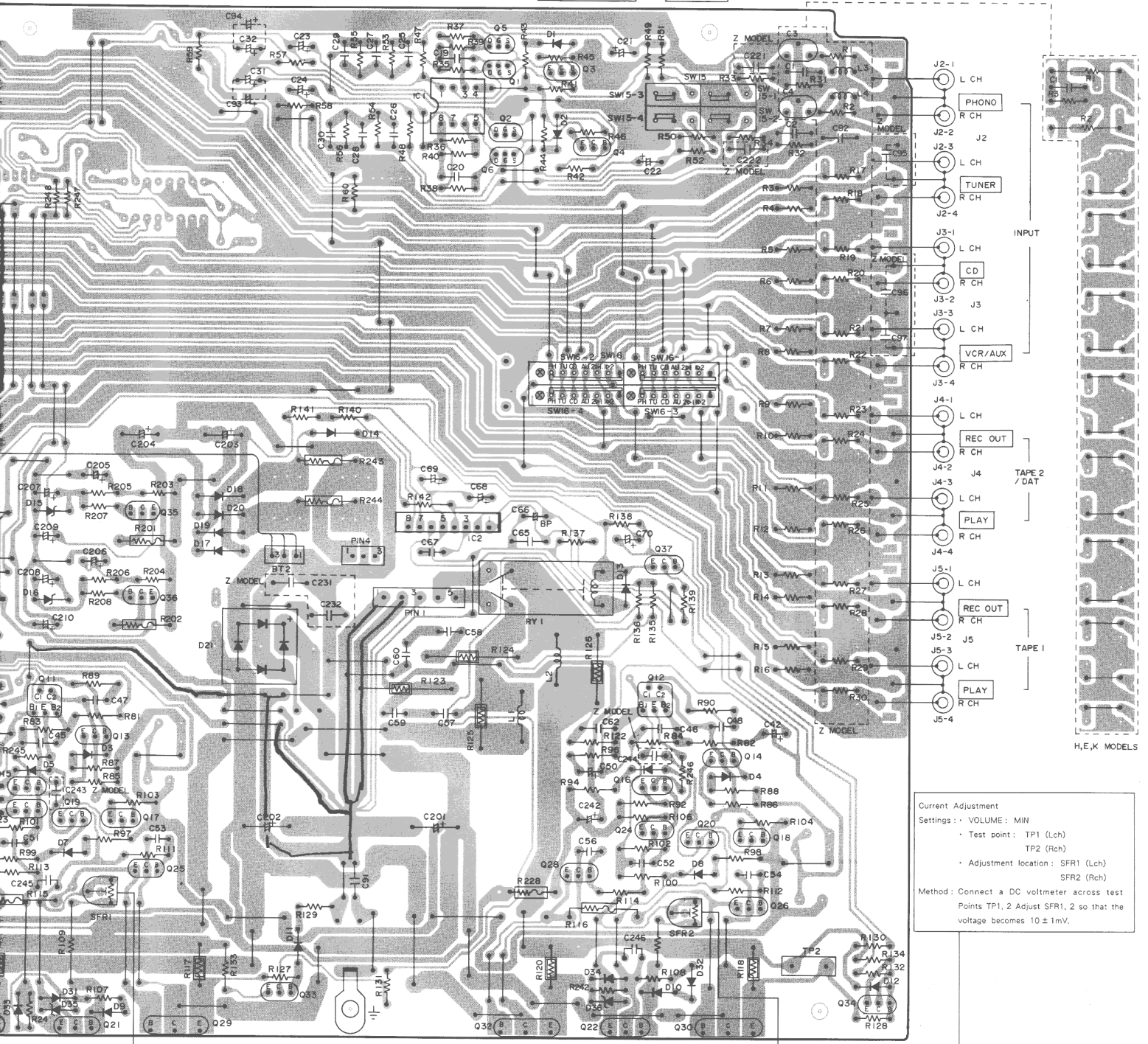

Current Adjustment
 Settings: - VOLUME: MIN
 - Test point: TP1 (Lch)
 TP2 (Rch)
 - Adjustment location: SFR1 (Lch)
 SFR2 (Rch)
 Method: Connect a DC voltmeter across test
 Points TP1, 2 Adjust SFR1, 2 so that the
 voltage becomes 10 ± 1mV.

1 2 3 4 5 6 7 8

A
B
C
D
E
F
G
H
I
J

B FRONT C.B.

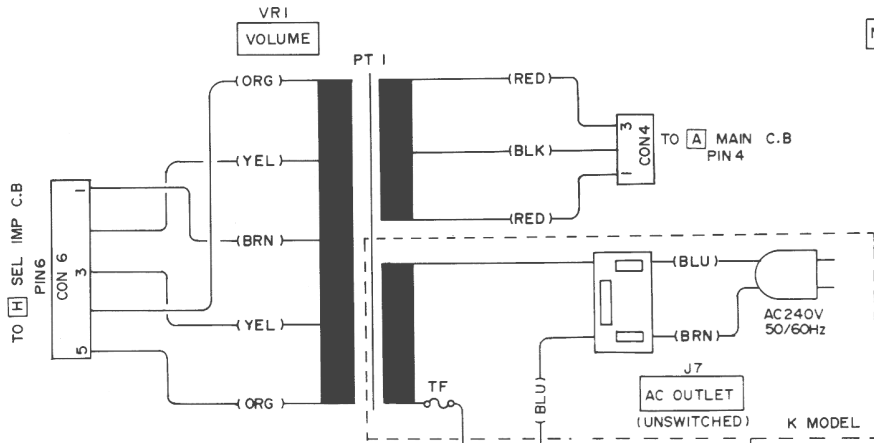
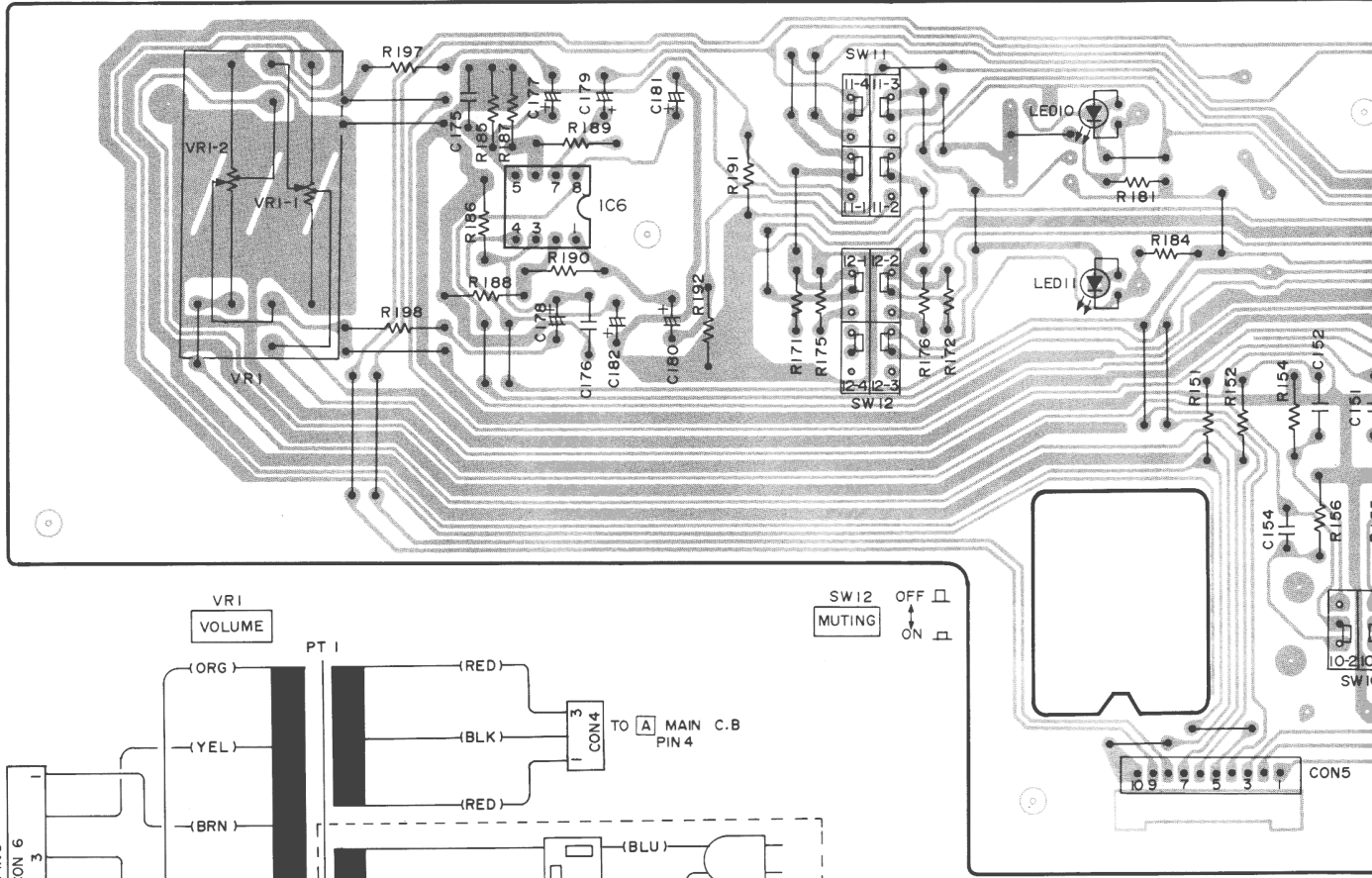

E POWER SW C.B.

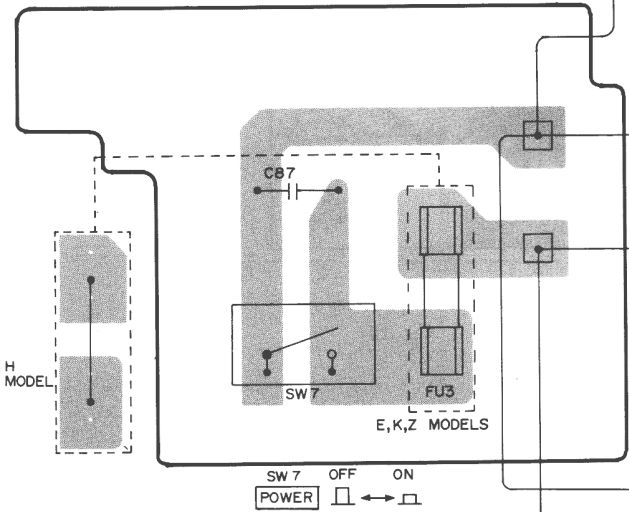

G OUTLET C.B.

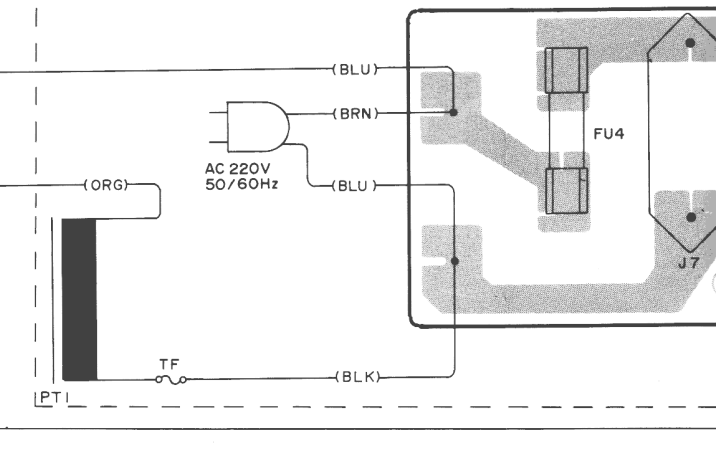

LED10
CD DIRECT
INDICATOR

LED11
MUTING
INDICATOR

SW14
TONE DEFEAT

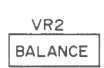
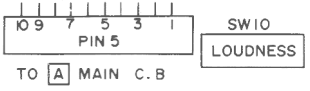
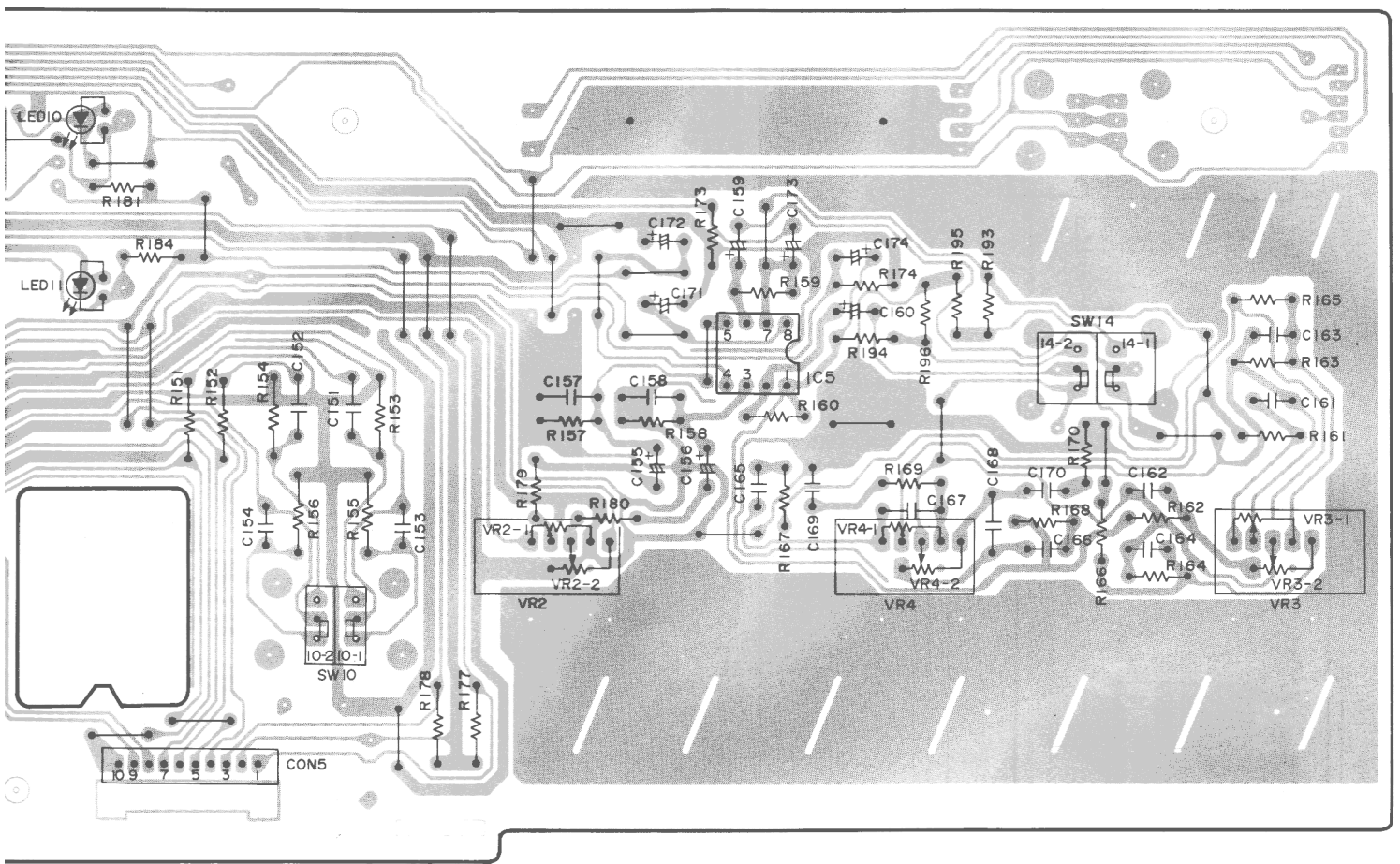

G OUTLET C.B.

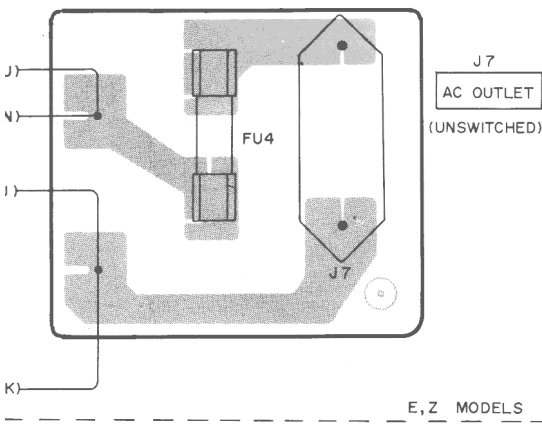

E, Z MODELS

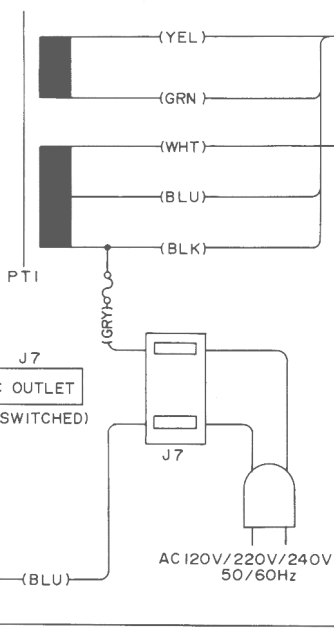

H MODEL

F AC VOLTAGE C.B.

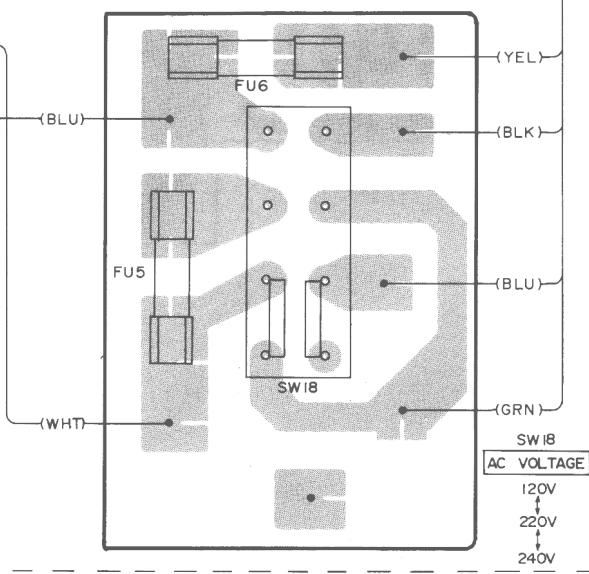

SW18 AC VOLTAGE 120V 220V 240V

EXPLODED VIEW - 1

REF. NO.	PART NO.	DESCRIPTION
A	87-067-579-01	BVT 2 + 3 - 8 W/O SLOT
B	87-067-688-01	BVTT + 3 - 6
C	87-067-660-01	BVT 2 + 3 - 8 W/O SLOT (B)
D	87-591-094-41	QIT + 3 - 6

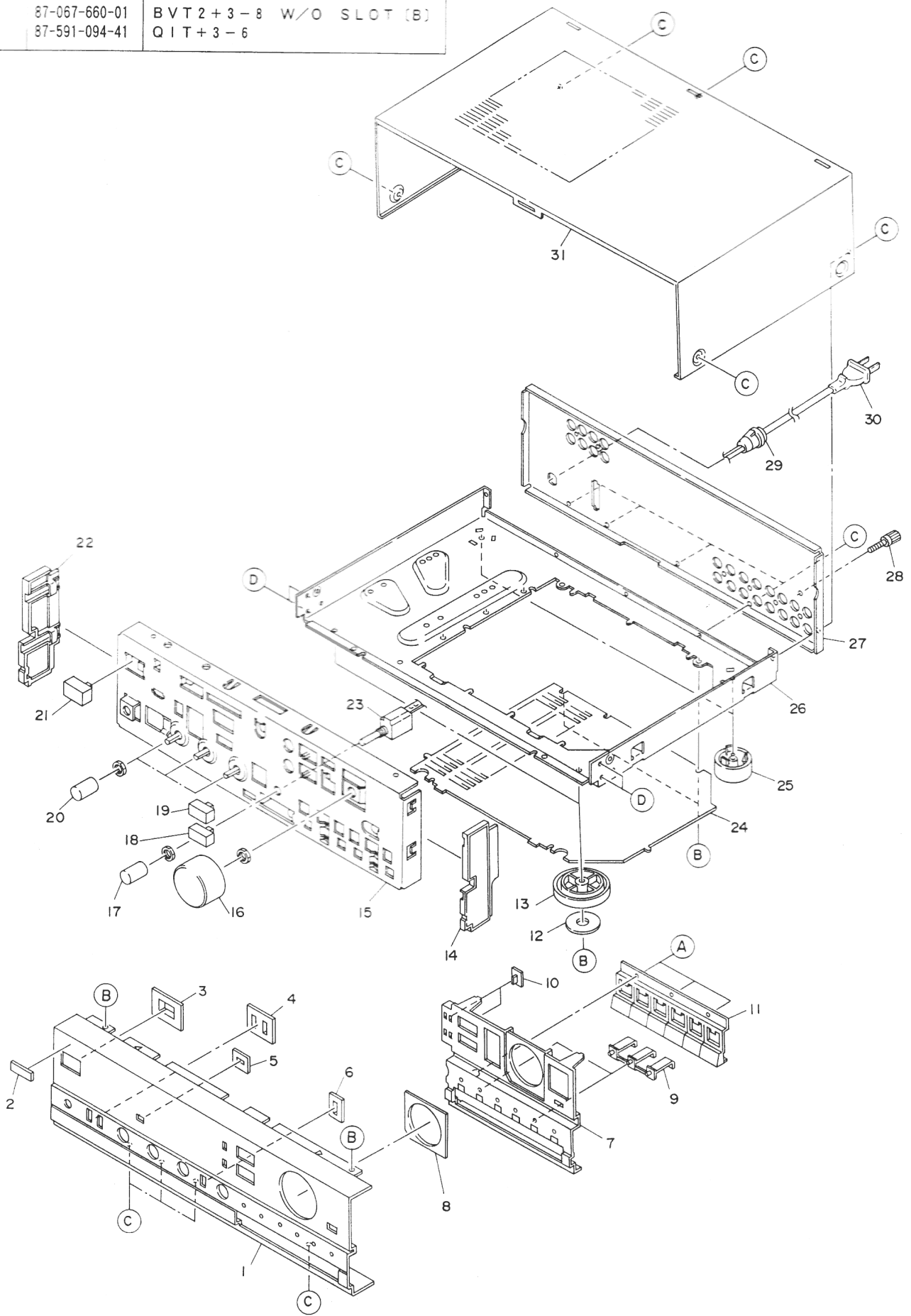

MECHANICAL PARTS LIST

PART NO. CHANGED TO	REF. NO.	PART NO.	DESCRIPTION	COMMON MODEL	Q' TY
	1-1	★89-AA1-001-010	PANEL, FR	※	1
	1-2	★84-764-009-119	BADGE, AIWA		1
	1-3	★89-AA1-023-019	GUIDE, POWER	※	1
	1-4	★89-AA1-026-019	GUIDE, LOUD	※	1
	1-5	★89-AA1-027-019	GUIDE, DEFEET	※	1
	1-6	★89-AA1-024-019	GUIDE, SPEAKER	※	1
	1-7	★89-AA1-025-019	HOLDER, FUNCTION	※	1
	1-8	★89-AA1-020-019	PLATE, VOLUME	※	1
	1-9	★89-AA1-021-019	GUIDE, LIGHT FUNCTION	※	2
	1-10	★89-AA1-022-019	GUIDE, LIGHT MUTE	※	2
	1-11	★89-AA1-013-019	BUTTON, FUNCTION	※	1
	1-12	★84-731-027-010	FELT, FOOT		2
	1-13	★84-738-022-010	FOOT		2
	1-14	★89-AA1-003-019	PANEL, SIDE R	※	1
	1-15	---	CHASSIS, FR		1
	1-16	★89-AA1-007-019	KNOB, ROTARY VOLUME	※	1
	1-17	★89-AA1-008-019	KNOB, ROTARY BALANCE	※	1
	1-18	★89-AA1-028-019	BUTTON, MUTE	※	1
	1-19	★89-AA1-012-019	BUTTON, DIRECT	※	1
	1-20	★89-AA1-009-019	KNOB, ROTARY SELECT	※	3
	1-21	★84-721-023-010	PUSH BUTTON POWER		1
	1-22	★89-AA1-002-019	PANEL, SIDE L	※	1
	1-23	★89-AA1-636-010	RMT SW, ASSY	※	1
	1-24	★89-AA1-207-019	PLATE, BOTTOM	※	1
	1-25	★89-AA1-006-010	FOOT	※	2
	1-26	---	CHASSIS, MAIN		1
	1-27	★89-AA1-040-019	PANEL, REAR (H)	※	1
	1-27	★89-AA1-041-019	PANEL, REAR (HJ)	※	1
	1-27	★89-AA1-038-019	PANEL, REAR (E)	※	1
	1-27	★89-AA1-037-019	PANEL, REAR (K)	※	1
	1-27	★89-AA1-039-019	PANEL, REAR (Z)	※	1
	1-28	87-033-209-019	TERMINAL EARTH		1
	1-29	★87-085-184-019	BUSHING AC CORD (H)		1
	1-29	★87-085-185-019	BUSHING AC CORD (E, K, Z)		1
	1-30	★87-034-749-019	AC CORD (H)		1
	1-30	★82-187-797-019	AC CORD (E, Z)		1
	1-30	★82-187-796-019	AC CORD (K)		1
	1-31	★89-AA1-004-010	CABINET, MAIN STEEL	※	1

EXPLODED VIEW - 2

REF. NO.	PART NO.	DESCRIPTION
A	87-067-579-01	BVT 2+3-8 W/O SLOT
B	87-067-688-01	BVTT+3-6
C	87-067-633-01	BVT 2+3-8 W/O CONVEX
D	87-067-639-01	BVT 2+3-10 W/O SLOT (R)
E	87-067-660-01	BVT 2+3-8 W/O SLOT (B)
F	87-067-585-01	BVTT+4-6

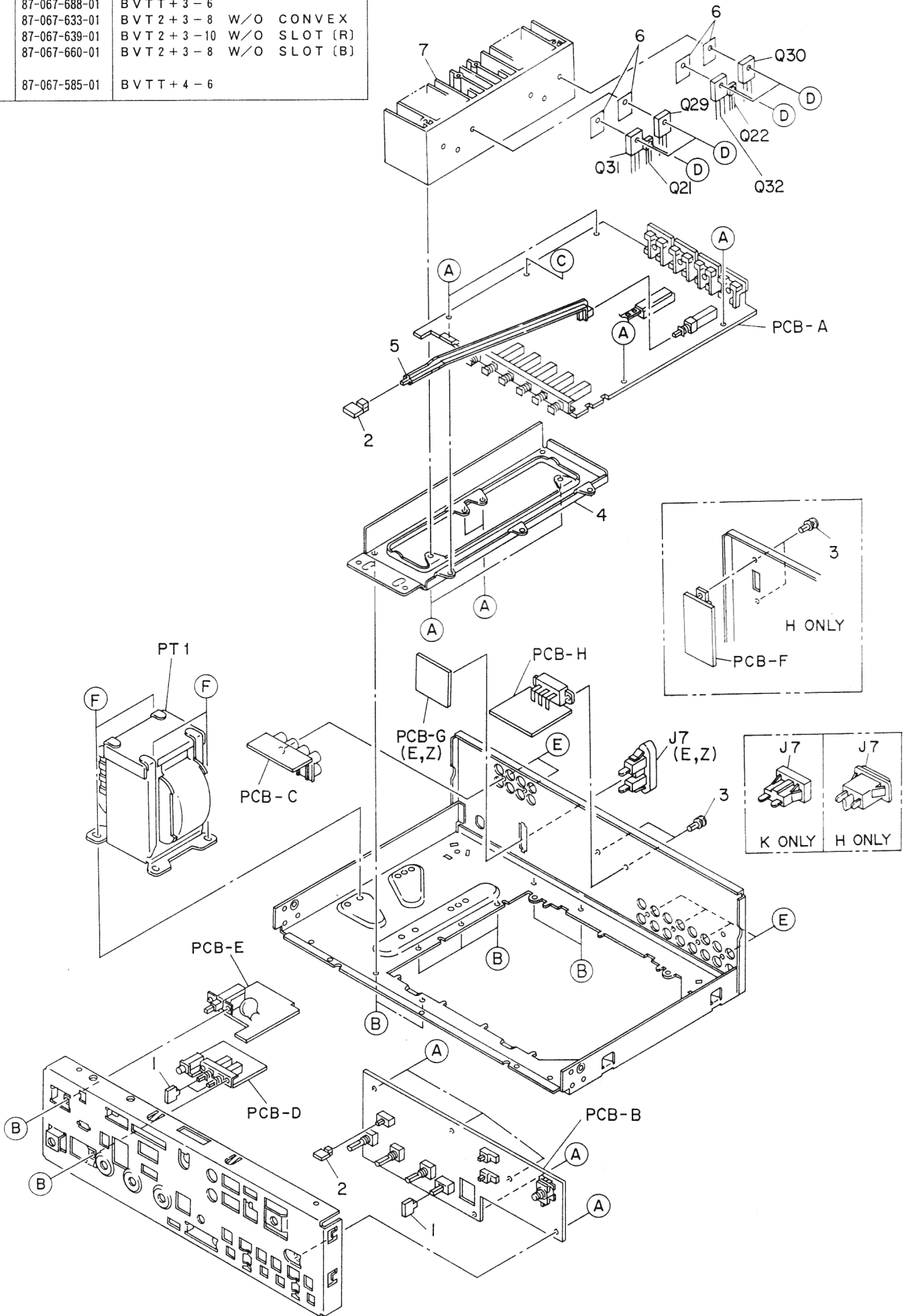

PART NO. CHANGED TO	REF. NO.	PART NO.	DESCRIPTION	COMMON MODEL	Q' TY
	2-1	★89-AA1-011-019	BUTTON, LOUD	※	3
	2-2	★89-AA1-010-010	BUTTON, DEFEET	※	2
	2-3	★87-084-063-019	RIVET NYLON 3-5.5	E, K, Z	2
	2-4	---	HOLDER, HEET SINK	H	4
	2-5	★89-AA1-206-019	ROD, MM/MC	※	1
	2-6	89-AA1-602-019	SHEET	※	4
	2-7	---	HEAT SINK ASSY		1

■ ACCESSORIES/PACKAGE LIST

PART NO. CHANGED TO	REF. NO.	PART NO.	DESCRIPTION	COMMON MODEL	Q' TY
	1	★89-AA1-911-119	INSTRUCTION BOOKLET E/K/Z	※	1
	2	★87-032-845-019	PLUG SIEMENS (H)		1